



Greater Dublin Drainage Scheme

Fingal County Council

TW/12/PRJ-007

19th September 2012

TechWorks Marine Limited

1, Harbour Road
Dun Laoghaire
Co. Dublin, Ireland

Private and Confidential

Contents

1. Introduction.....	3
1.1 Site Location	3
2 Equipment.....	4
2.1 Marker Buoy.....	5
2.2 Oceanographic Sensors	6
2.3 Mooring Configuration.....	7
2.4. Deployment Vessel Specifications.....	7
3. Health & Safety	8
4. GDDS Mooring Deployment Report.....	8
4.1 GDDS Mooring ROV Survey.....	12
5. Tide Gauge Deployment.....	15
5.1 Howth.....	15
5.2 Skerries.....	16
6. Recovery.....	17
6.1 Recovery Report.....	17
7. Deployment Map.....	21
8. Data.....	23
8.1 SBE 37 MicroCAT.....	23
8.2 Current Measurements.....	24
8.2.1 Site A.....	25
8.2.2 Site B.....	26
8.2.3 Site C.....	26
8.3 SBE 39 Tide Gauges.....	27

1. Introduction

TechWorks Marine has been commissioned by Fingal council to deploy 3 environmental monitoring buoys at three locations each measuring conductivity and temperature at 3 points in the water column. Along with the deployment of the buoys, TechWorks will be deploying 3 frames on the seafloor which will measure the current speeds at each site. These instruments will be deployed for a period of 1 month with a view to characterise the fate of pollutants from the proposed new outfall pipe from a waste water treatment plant. In addition to this, two tide gauges will be placed at strategic coastal locations to collect temperature and sea surface height data.

1.1 Site Location

- ADCP 1 : 53.5550degN, -6.0540degE (bed level 15m)
- ADCP 2 : 53.4875degN, -6.0650 degE (bed level 13m)
- ADCP 3 : 53.4155degN, -6.0450degE (bed level 23m)

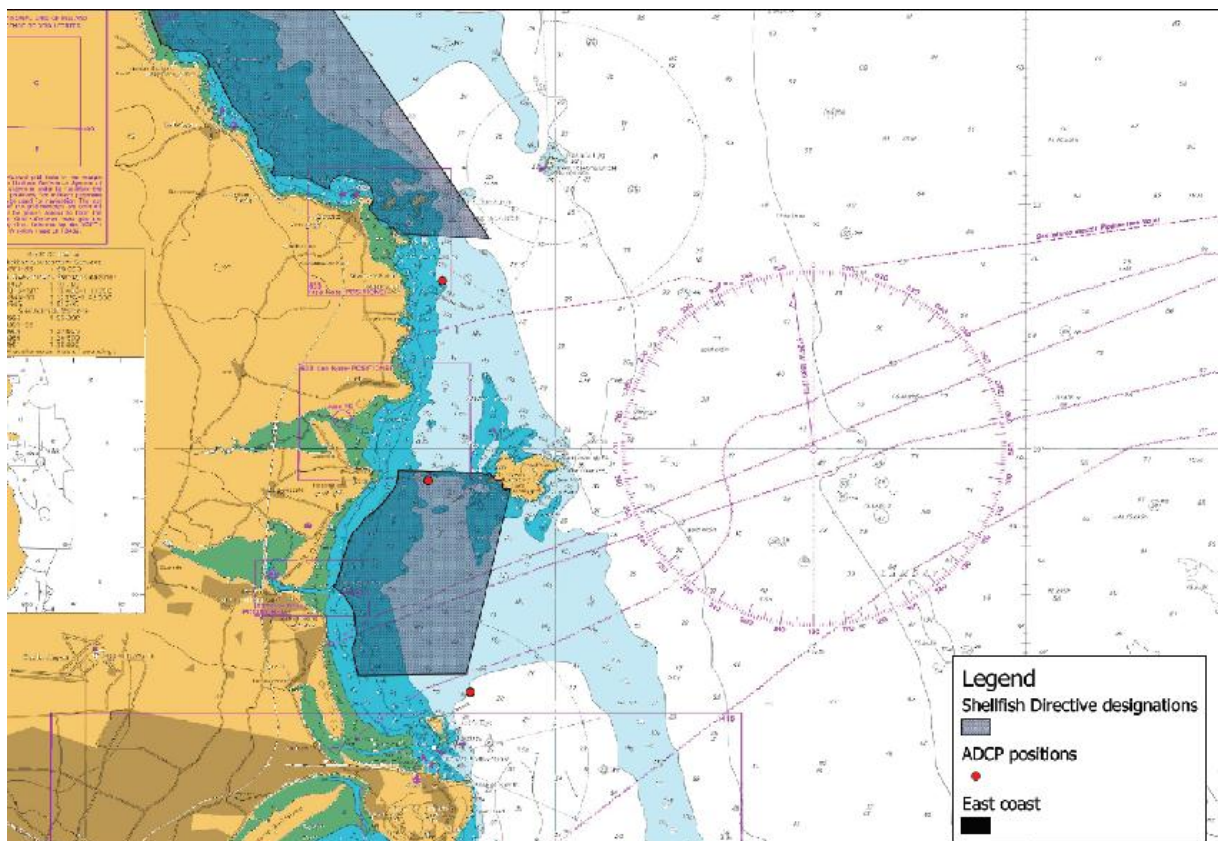

Figure 1. Ordnance Survey Map with overlay showing the proposed deployment sites

2. Equipment

	Equipment	Quantity	Serial Number
Mooring	Anchor chain (500kg)	3	
	Binding chain (4m)	3	
	Joining shackle	16	
	Jacketed wire Mooring line(25m) 12mm	3	
	Swivel shackle	9	
	Seizing wire	1	
Buoy	Mobilis Buoy	3	
	Stainless Steel Frame	3	
	SeaLite SL70.Y Nav Light	3	
	Radar reflector	3	
	Techworks Marine sticker	3	
	'Scientific Buoy' lettering	3	
Frames	MSI Frame	2	
	AQUADOPP frame		
	AWAC Battery pack	2	
	Lead weight (250kg/frame)	3	
Instruments	SBE 37 SM	5	37SM68821 - 3108
			37SM68821 - 3109
			37SM68821 - 3112
			37SM68821 - 3113
			37SM68821 - 3115
			37SM68821 - 6057
	SBE 37 SMP	4	37SMP68821-9517
			37SMP68821-9518
			37SMP68821-9519
			37SMP68821-3947
	SBE 39	2	3958008-5224
			3958008-5225
	AWAC	2	N- 6239
		N-6235	
AQUADOPP	1	AQP - 2932	

2.1 Marker Buoy

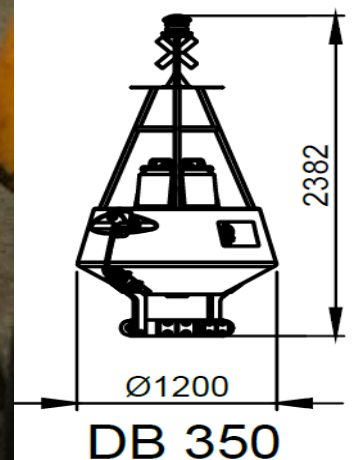
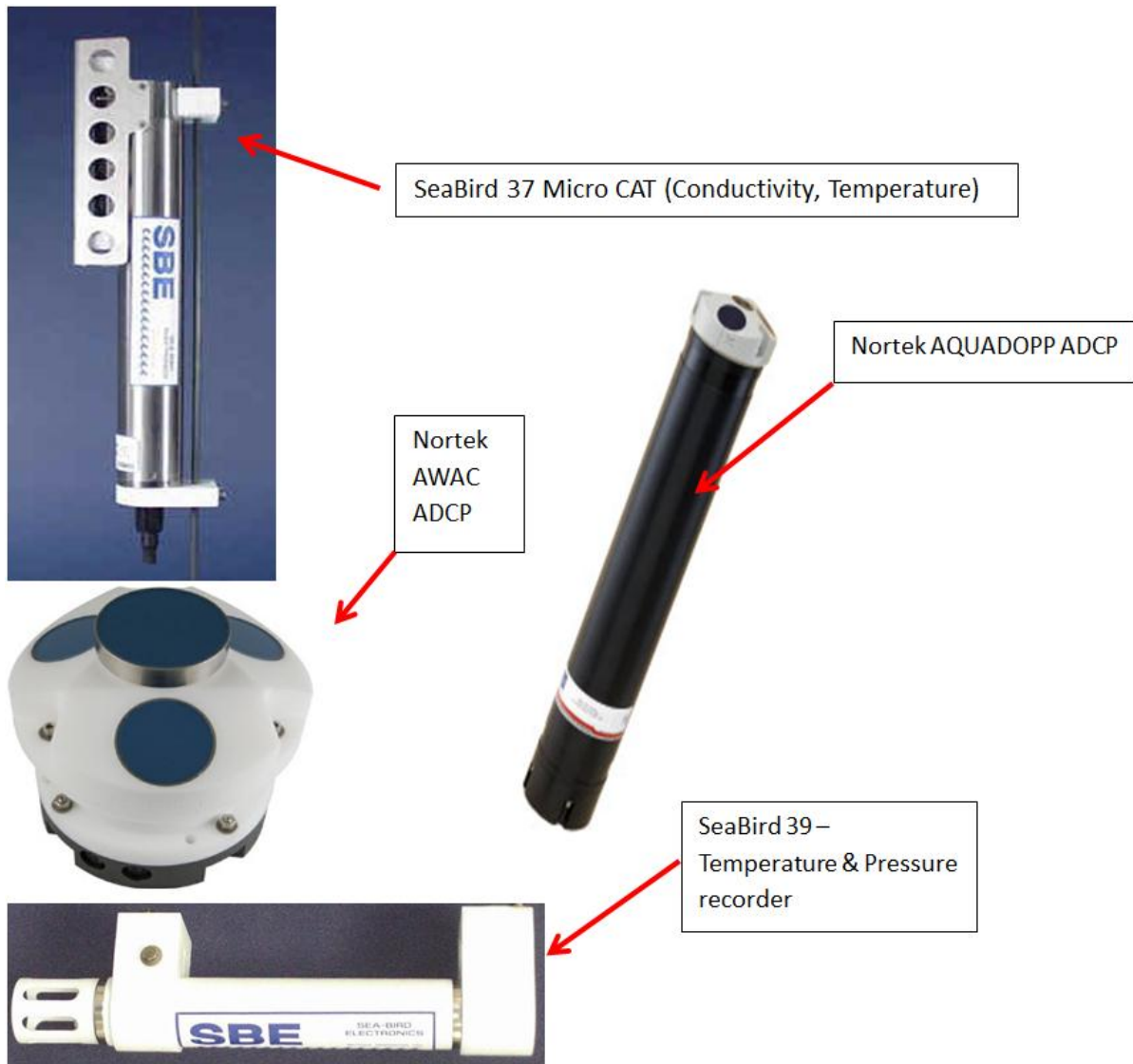

Figure 2. The Mobilis marker buoy has a radar reflector and navigation light programmed to flash 5 times every 20seconds. Combination cable cable has been chosen for the mooring as it offers extra strength and allows instruments to be clamped on without coming under any strain forces.

2.2 Oceanographic Sensors



Sea-Bird Electronics, Inc. is the leading manufacturer of oceanographic CTDs. The sensors used in the project have become recognised as the industry standard for accurate oceanographic measurements. Nortek develop state-of-the-art ADCPs (Acoustic Doppler Current Profilers) which are simple to use and offer very accurate wave and current measurements.

2.3 Mooring Configuration

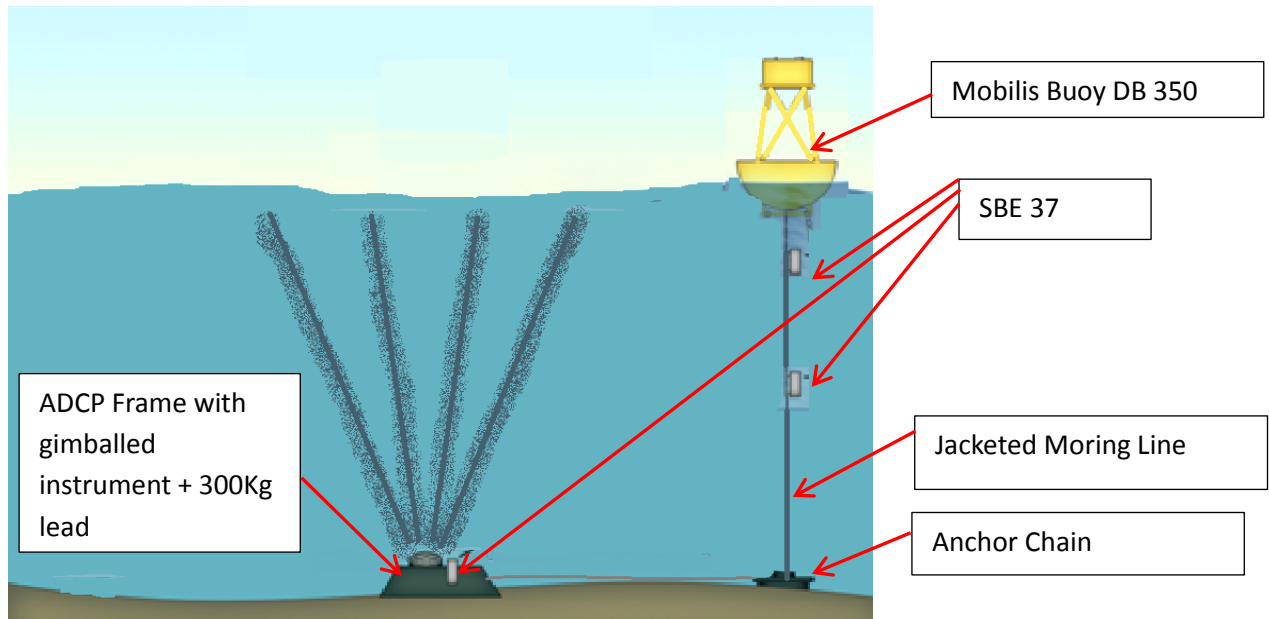

2.4 Deployment Vessel Specifications

<p>General Type of vessel: 3 Hulled Multicat Yard Number: MC 05 Year of build: 2009 Basic functions: Surveying, Crew change Oil pollution control, Offshore Wind-farm support Bird/Whale watching etc. Passenger License: P5 for 12 persons National Authorities: UK workboat code / CAT 3</p>	<p>Accommodation 1 Fully heated cabin/ Separate WC Fully equipped galley</p>	<p>Dimensions Length OA: 15.50m Beam OA: 8.5m Draft: 0.8m Gross Tonnage: 22.7 Speed Light: 8 kts Bollard Pull: 3.5 tonnes</p>
<p>Road Transport Specification (L x W x H x weight) Starboard Hull 15.5m x 3.12m x 2.7m x 19.8t Centre Hull 15.5m x 2.9m x 2.7m x 16t Port Hull 15.5m x 3.12m x 3.85m x 23.2t</p>	<p>Nautical Equipment 1 x Furuno Navnet GPS Plotter 1 x Furuno Sounder 1 x Furuno Radar 1 x ICOM Vhf</p>	<p>Tank Capacities Fuel oil: 4700 Litres Fuel Cargo 11000 Litres Fresh Water cargo: 24000 litres</p>
<p>Road Transport Specification (L x W x H x weight) Starboard Hull 15.5m x 3.12m x 2.7m x 19.8t Centre Hull 15.5m x 2.9m x 2.7m x 16t Port Hull 15.5m x 3.12m x 3.85m x 23.2t</p>	<p>Deck Layout Deck area: 112 m2 Deck Rating: 7.5 tonne per m2 Winch: 1 x drum 5 tonne with capstan Crane: Palfinger PK 23500M 1570 kg@ 12m Deck cargo 28 tonnes A Frame: 4 tonnes Moonpool: 1200mm</p>	<p>Propulsion system Main Engines: 2 x Doosan L136T I Generator 1 x 9.2 KVA Westerbeke</p>

Figure 3. SMS Meercat. The vessel is being procured from SINBAD marine services ltd registered in Killybegs, Co Donegal, Ireland.

3. Health and Safety

For a full and comprehensive description of the H&S and risk assessment of this project, please see the attached documentation. (GGDS H&S Plans.xls)

4. GGDS Mooring deployment report

TechWorks Marine Personnel – Philip Trickett (Technical Director), Adam Partington (Marine Scientist), Kieran Harper (Remote Sensing specialist)

12/07/2012

07:45- Mobilised team and equipment from TechWorks offices to Pigeon House Rd Pool to meet the Deployment vessel (SMS Meercat).

08:20 – Used the vessel’s deck crane to load all equipment on board

08:37- Safety briefing carried out by Meercat crew: - Declan (Captain) and Nigel (Engineer). TechWorks explain deployment plan and order of events.



Figure 4. On board the SMS Meercat adding ballast to the Aquadopp frame

09:00 – The team leaves Pigeon House Rd Pool and heads to site A. During transit the

Fingal County Council

equipment is checked over and the lead is attached to the ADCP frames for ballast. The Jacketed mooring cable is cut to required length using an angle grinder and secured to buoy and sinker chain. All instruments are programmed and switched to sampling mode.

12:15 – Team arrives at first site at low tide. Depth at site is 12.8m and so SBE 37 depth is positioned at 9m along the mooring cable to allow for range in water level.

12:20 – Buoy lifted into water and then roped to the side of the vessel while the Meercat repositions itself at desired GPS co-ordinates

13.01 – Anchor chain released to Seafloor at position $53^{\circ}33'.1824$ N, $006^{\circ}03'.1632$ W

13.10 – Aquadopp frame lowered to Seafloor and buoy released from vessel

13.30 – VideoRay ROV mobilised and deployed. Tidal current very strong at this point and ROV struggles against the force pulling against the tether. Within 90secs of deployment the vessel has drifted >100m from the buoy.



Figure

5. The VideoRay ROV entangled around the marker buoy which had to be lifted to undo the tether

13.40 – The VideoRay is recovered and the vessel makes another sweep past the Buoy and the ROV is deployed. Images of the buoy and the two SBE 37s on the mooring cable can be seen but as the ROV reaches the Seafloor; the tidal current has dragged it too far from the

anchor chain to find the frame. The seafloor is noted as being sandy and flat. The propellers from the deployment vessel have also disturbed some of the sediment reducing visibility and coordination.

13.55 – The team decide to bring in the ROV and make one more attempt to get a shot of the frame on the Sea floor. As the vessel makes another sweep at the buoy, the ROV is deployed but the tether gets wrapped around the mooring cable as the vessel drifts past. Recovery by piloting the ROV out of harm’s way becomes impossible and so the deck crane is used to lift the buoy from the water and detach the ROV. The tether has suffered some damage from the strain it came under and as a result, could not be further utilised.

14.45 – The Team mobilise to the next deployment site.

15.55 – Arriving at site B the team mobilise the second set of equipment. The depth to the seabed is 15m

16.15- Buoy is positioned in the water and secured to the stern of the vessel



Figure 6. The deck crane being used to lift the AWAC trawl-resistant frame into the water

16:25 – Anchor chain released to the seabed at 53°29'.1605 N, 06°03'.5428 W

16:27 – Frame lowered to the seafloor and the buoy is released form the vessel.

16.45 – Vessel mobilises to site C



Figure 7. Quick release shackle attached to vertical steel pole.

17.44 – Team arrives at site C and prepare the final set of equipment for deployment. The deployment polyprop rope used in the previous deployment had to be left submerged with the second frame after complications meant that it could not be recovered. As a result a new plan is devised using a ‘quick release’ shackle to lower the frame into position and then use a thin rip cord to release the set-up once the frame reaches the seafloor. (See photo)

18.36 - Buoy is lowered into water and secured to vessel

18:40 – Anchor Chain released to seafloor at position $53^{\circ}24'.5552$ N , $006^{\circ}02'.3954$ W. As the frame reaches the seafloor the rip cord is pulled but the team are unable to generate enough horizontal force to remove the pin from the shackle. As a result, the deployment rope remains attached to the frame. To ensure the rope doesn’t float above the instrument, one of the team attaches an anchor chain shackle to the end of the rope to sink it out of harm’s way.

19.10 – The vessel returns to Dublin port.

Fingal County Council

The team agree to return to the sites in a smaller vessel capable of mooring onto the buoys, allowing them to deploy the ROV to get a visual on the frames. The ROV has been scheduled for repair which should be completed by 19/07/2012.

Summary

Site	GPS	Equipment	Serial Number
A	53°33'.1824 N , 006°03'.1632W	Aquadopp 3*SBE 37	N-135, 3112, 3115, 9518
B	53°29'.1605 N , 06°03'.5428 W	AWAC 3* SBE 37	N-6239, 3113, 9517, 3109,
C	53°24'.5552 N , 006° 02'.3954 W	AWAC 3* SBE 37	N-6235, 3108, 6057, 9519

4.1 Mooring ROV Survey – 20/07/2012

TechWorks Marine Personnel – Philip Trickett, Adam Partington

The following week TechWorks Marine mobilised the VideoRay ROV to the Survey sites in a smaller RIB and moored onto the buoys. Footage was shot of the SBE 37's, anchor chain and frames on the seabed to ensure their orientation were correct.



Figure 8. Deploying the ROV from the boat. The deck console is shown which along with the laptop used for recording the video stream to file.



Figure 9. Underside of the marker buoy with swivel shackle connected to mooring cable



Figure 10. SBE 37 MicroCAT moored on the jacketed combination wire at 7.5m



Figure 11. Anchor chain on the seabed at 14m. The two mooring lines coming off the sinker chain lead to the buoy and the AWAC frame.



Figure 12. Gimballed mounted AWAC in trawl resistant frame

5. Tide Gauge Deployment

TechWorks Marine Personnel – Philip Trickett, Adam Partington

Tidal level is measured in relation to the Datum at Malin head. The Marine Institutes tidal gauge network has tide gauges positioned all around the Irish coastline including one in Howth and Skerries. RTK surveys had previously left a metal pin in the ground at both sites at a known distance above the Malin Head datum. TechWorks measured the distance of the SBE 39 tide gauges from this pin so the depth of the tide gauge could later be converted to depth in relation to the datum.

The SBE 39 tide gauges were fastened to the end of a stainless steel pole and lowered approximately 1 metre below the surface at low tide. The distance from the pin on the floor of the pier to the tide gauge was measured.

5.1 Howth

Howth Tide gauge – deployed 17/07/2012 Latitude 53.391358 Longitude -6.068208

Datum measurements

Distance from tide gauge to metal pin	Offset of pin from Datum at Malin head	Correction
5.99m	3.395cm	2.595m

(Note:- In excel tide gauge enters water at 19.29- cell number 703)



Figure 13. Metal pin in the ground on the pier in Howth Harbour. The RTK surveys carried out by the Marine Institute places this point 3.395m above the Datum at Malin Head.



Figure 14. Marine Institute Bubble Tide gauge. TechWorks fastened a pole and Pressure tide gauge to the base of this pipe.

5.2 Skerries

Skerries Tide gauge – deployed 17/07/2012 latitude 53.585039 longitude -6.107942

Datum Measurements

Distance from tide gauge to metal pin	Offset of pin from Datum at Malin head	Correction
6.92m	3.291cm	3.629m

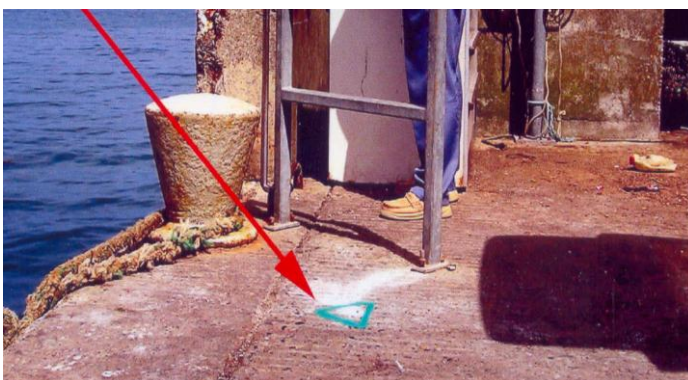

Figure 15. The Metal Pin in the ground on the Skerries Harbour pier. The RTK survey carried out by the Marine Institute places this point at 3.291m above the Datum at Malin Head.

6. Recovery

The Recovery of three buoys and frames was scheduled to take place commencing the week of 13/08/2012. The vessel used during the deployment (SMS Meercat) was no longer available for hire so a new vessel was been procured. The 'Cluaran', a 35ft converted Razor clam trawler with a deck crane and a 3.5tonne winch (see picture) was hired for the day along with two crew members. The boat and its crew are responsible for deploying and recovering the racing marker buoys used by Howth Yacht Club and so had experience with such operations.

The deployment was delayed while TechWorks waited for Aquafact to complete the Drogue and Dye surveys which required spring tides and calm weather.

6.1 Recovery Report

23/08/2012.

TechWorks Marine Personnel – Adam Partington, Kieran Harper



Figure 16. The Cluaran recovery vessel with 1.5 tonne deck crane and 3.5 tonne winch

04:45 - TechWorks marine mobilise to Howth harbour

05:30 - Rendezvous with the Cluaran and its skipper Monty to run through recovery plan,

Fingal County Council

health and safety.

05:45 - Head to the first site at Howth (Site C).

07:00 – Arrive at first site and use A- frame and winch to load the first buoy clear of the water. The swivel shackle and jacketed mooring cable is secured to the vessel's gantry and the buoy is secured to the side of the vessel.

07:15 - The first SBE 37 is released from the mooring cable by loosening the clamps and its serial number and position in water column is noted.



Figure 18. The anchor chain being brought up by the vessel's gantry.

07:30 – The buoy is brought onto the deck using the crane and secured on the port side of the vessel.

The mooring cable was then loaded onto winch and hauled up.

The second SBE 37 is detached as it clears the water.

The Anchor chain surfaces and is brought up onto the deck of the boat. The shackle is released from the anchor chain and the polyprop rope is loaded onto the winch.



Figure 19. The AWAC frame breaching the surface

The winch is used to haul up the first AWAC frame and the gantry is then tilted to bring the frame onto the deck. Recover ADCP frame. Steam to second site.

09:00 – During transit to second site, all instruments are detached from the frame and stored in a storm Pelicase. The lead ingots are removed and stacked to allow frames to be shifted around the deck to free up space for subsequent recoveries.

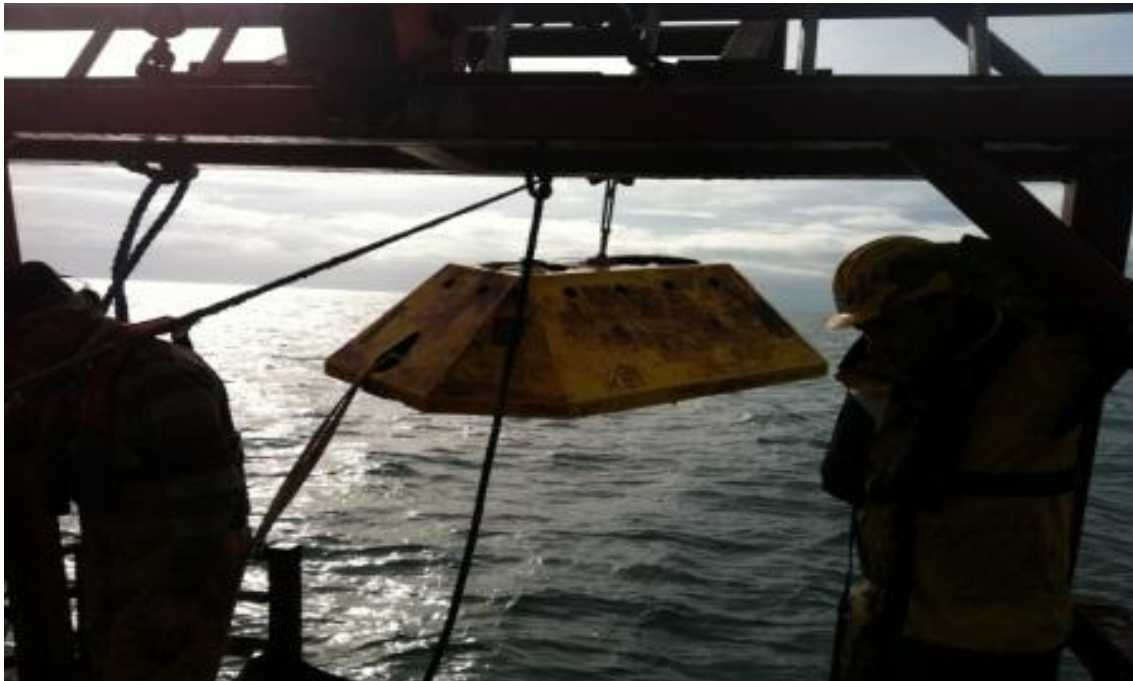

Figure 20. The second frame lifted clear of the water

09:45 – Arrive at site to for slack water (09:47) and repeat recovery procedure.

11:30 – Arrive at third site and repeat recovery procedure

12:00 – Steam to DunLaoghaire

16:00 – Arrived at Carlisle Pier (DunLaoghaire) and offload all equipment and instrumentation using vessel crane. All buoys, anchor chain and frames are stored on pallets on the pier overnight. Harbour police secure gates of Pier.

18:00 - Instruments are brought back to TechWorks offices and stored



Figure 21 & 22. The recovery vessel moored up on the Carlisle Pier in DunLaoghaire. The vessel's crane was then used to lift all equipment onto the pier before it returned to Howth harbour.

24/08/2012

09:00- Use pallet lifter to bring all equipment back to offices

7. Deployment Map

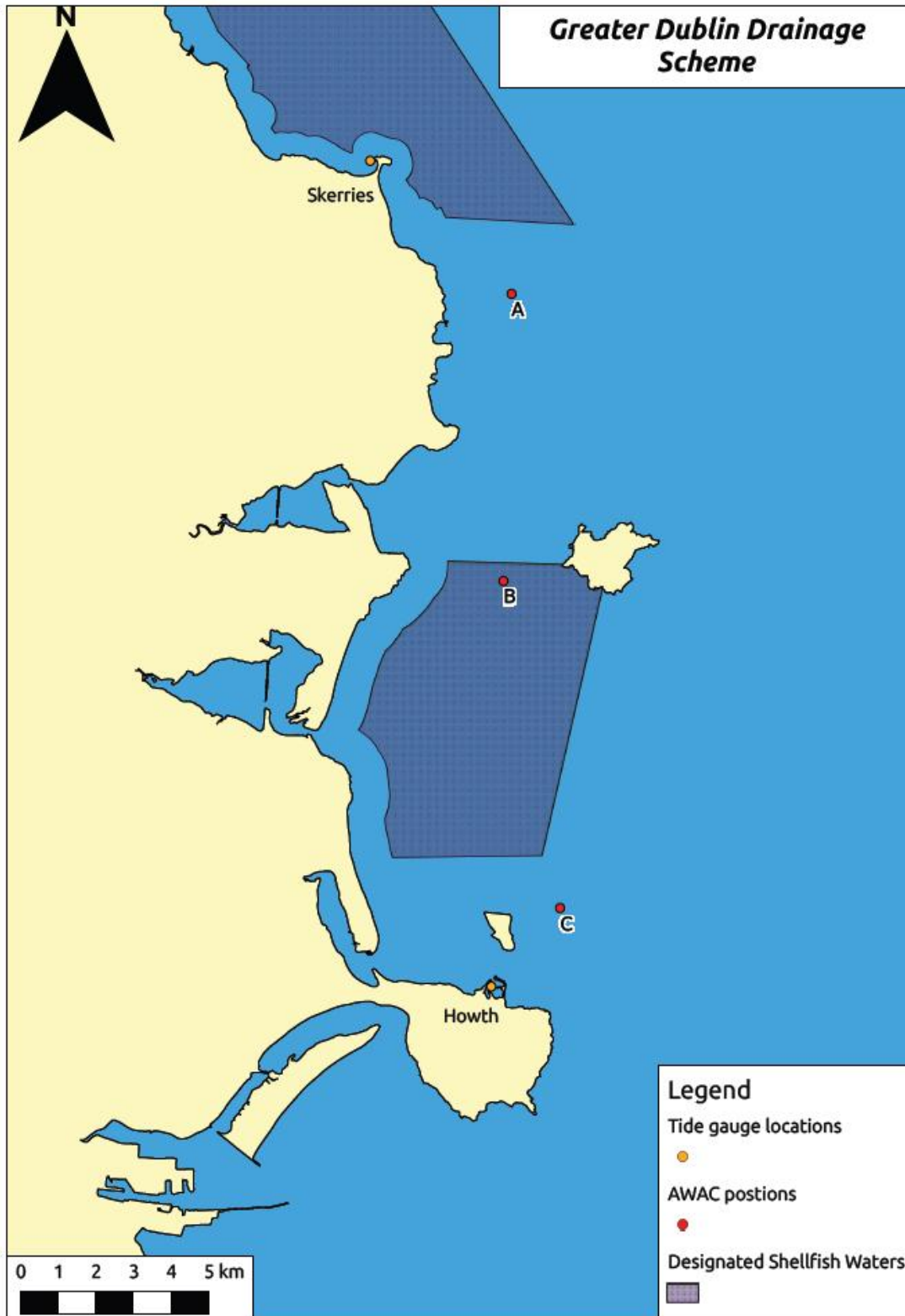

Figure 23. Map showing the deployment sites for the current meters and the tide gauges



Figure 24. Google earth Image of study area including the positions of the Temperature, Salinity and Current measurements.

8. Data

8.1 SBE 37 - MicroCAT

The raw data from the SBE 37 was uploaded using the SBE SeaSoft software. RAW ASCII files were uploaded from each instrument which includes temperature and conductivity along with the date and time for each sample. Seabird data processing tools were then used to derive salinity values from the conductivity values. These ASCII files were then converted to .csv files to be opened in excel before the temperature and conductivity data was separated into individual cells. The processed data was then saved as an excel workbook. (Copies of all data files have been provided). Below is a snapshot of the data from one of the SBE 37.

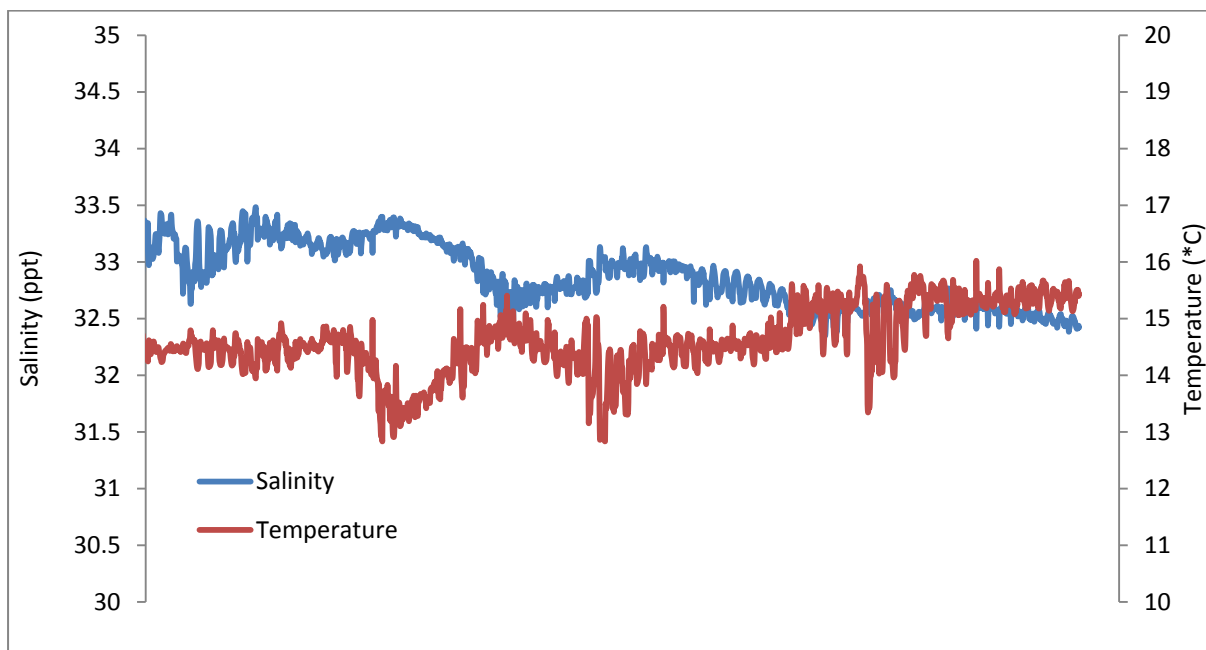

Figure 25. Graph showing the Salinity and Temperature values for the deployment period.

Note: Temperature values are in degrees Celsius. Salinity values are in parts per thousand.

8.2 Current measurements

Data from the AWACs and Aquadopp were uploaded using Nortek’s AWAC AST v. 1.42 and AquaPro v. 1.35 respectively. The raw data was then run in Storm v. 1.13 (current data display and analysis programme). The processing software tools were then applied to the data using the following default settings

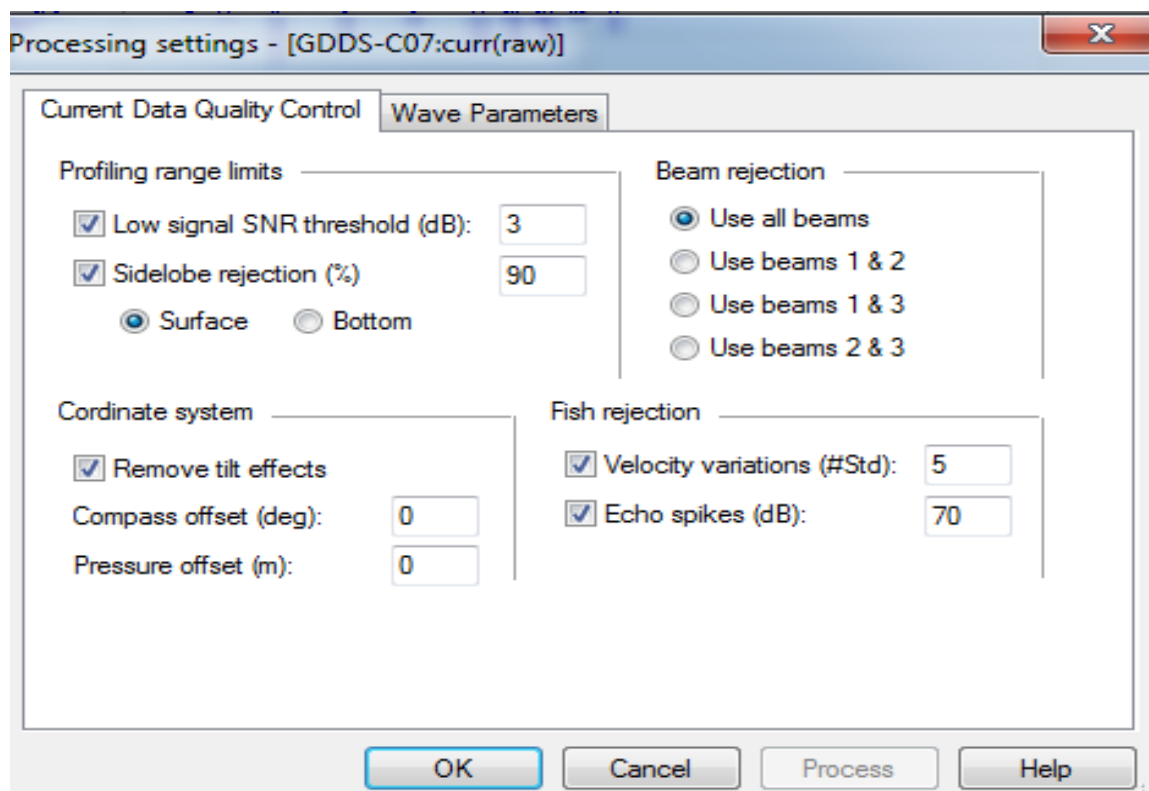

Figure 26. Screen snapshot of the data processing settings applied to the raw AWAC and AquaDopp data.

A maximum signal level threshold was chosen to remove spikes in data (from fish or other false targets). The surface was located by finding the peak in the acoustic return. All data files (raw and processed) have been submitted to the client.

Snapshots of the data from the Storm software are displayed overleaf (Site A, B, C respectively). All data files have been submitted to the client.

8.21 Site A

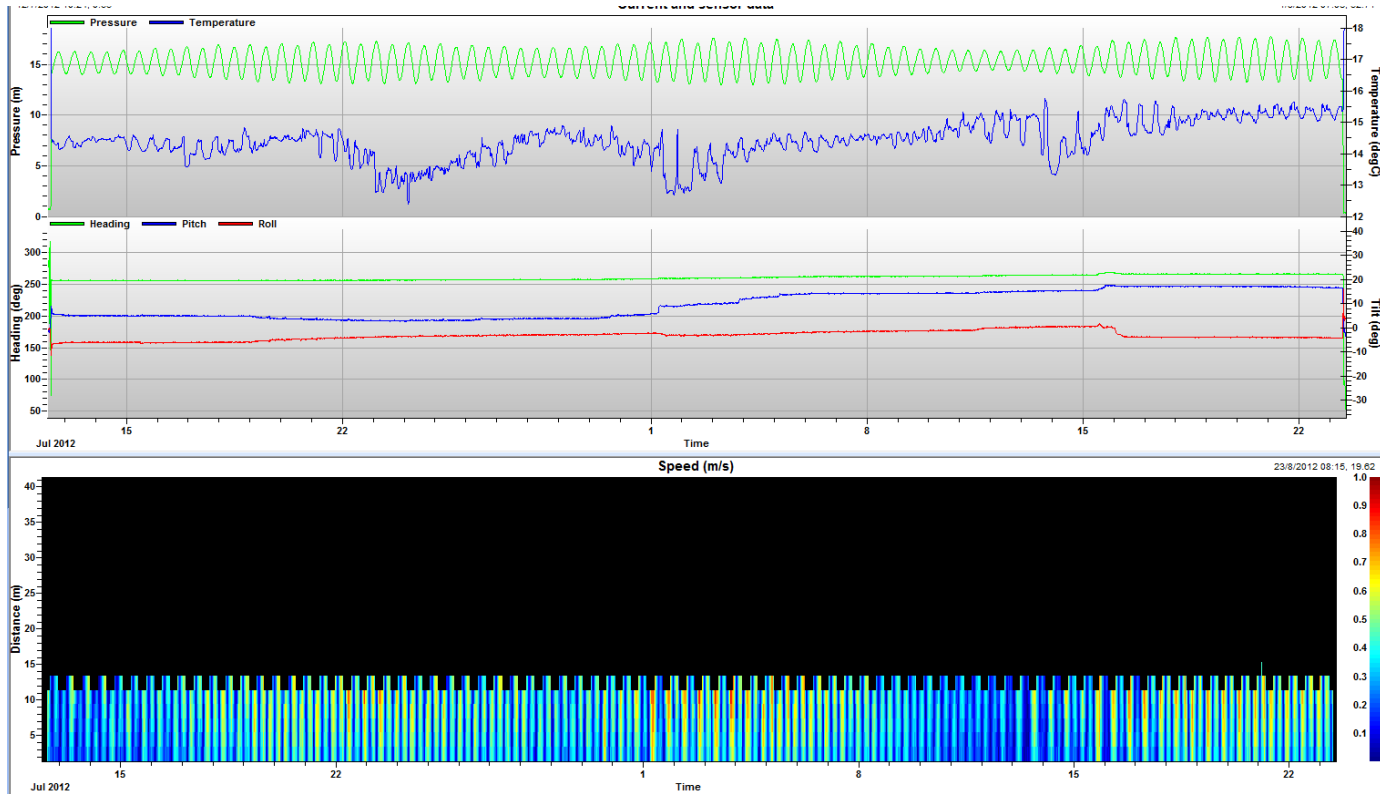

Figure 27. Screen snapshot of Storm showing current data from site A

The image above showing a snap shot from the Storm software shows the fluctuating pressure at the surface (green line- top graph) which represents the shifting depth of the water column with tides. The second graph shows the orientation of the ADCP with heading (green), Pitch (blue) and roll (red). The bottom graph shows the current speed through the water column. The colour scale runs from 0m/s (blue) to 1m/s (red). The peak current speeds are associated with the spring tides.

8.2.2 Site B

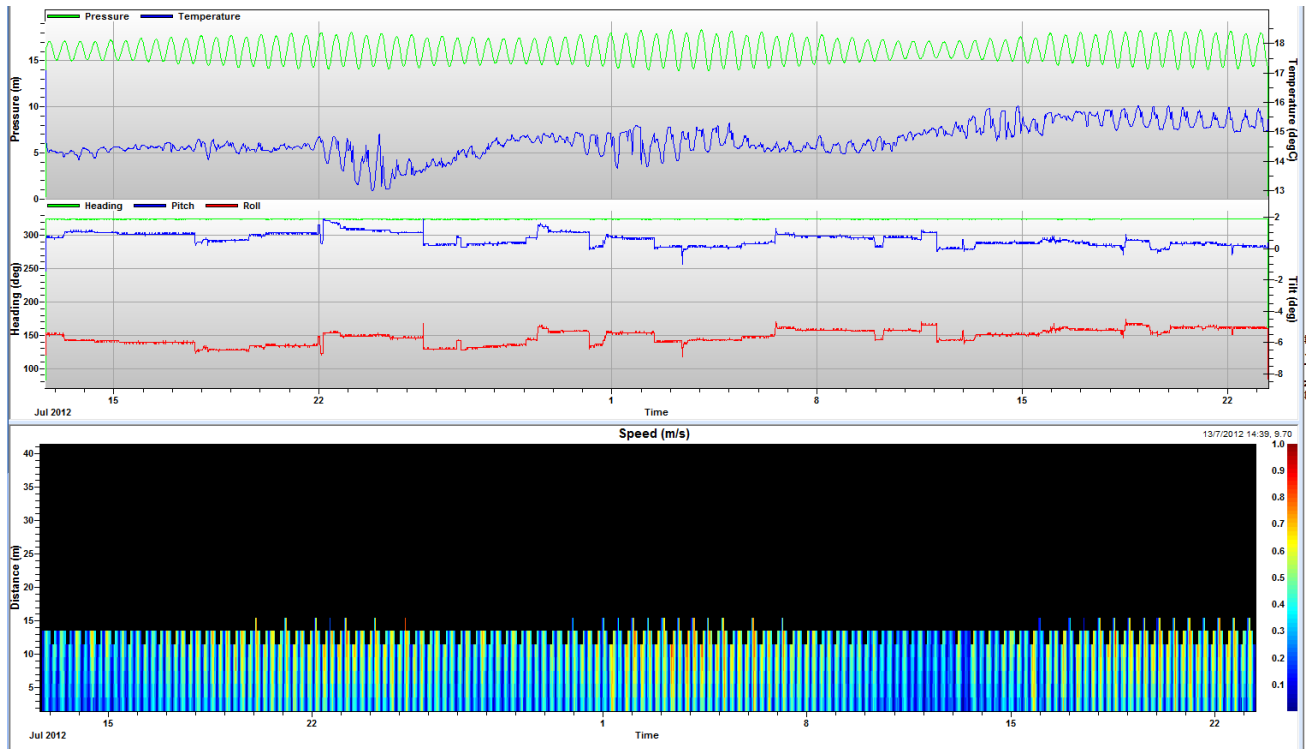

Figure 28. Screen snapshot of Storm showing current data from site B

8.2.3 Site C

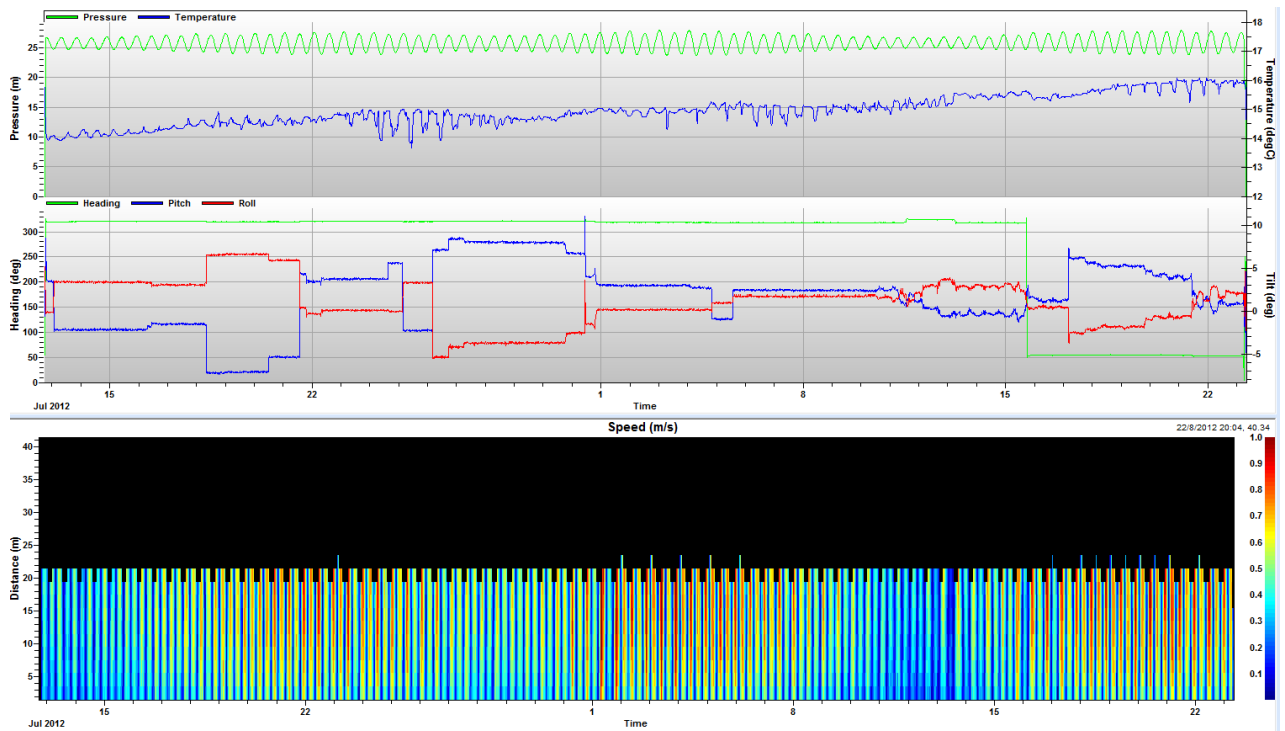

Figure 29. Screen snapshot of Storm showing current data from site C

8.3 SBE 39 Tide Gauges

The raw data from the SBE 39 was uploaded using the Seaterm emulator as an ASCII file and then converted to a .cnv file.

An initial check of the data was made using SeaPlot 39 (screenshot below)

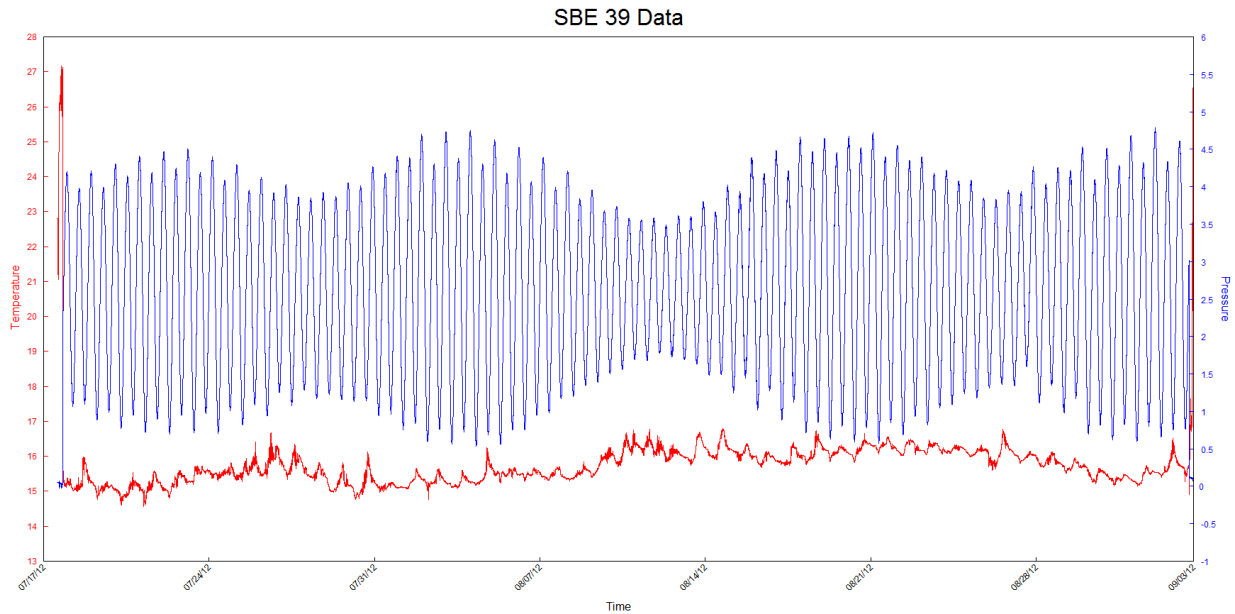

Figure 30. SeaPlot graph showing Pressure (dBar) and Temperature (Celsius) for the duration of the SBE 39 deployment.

The pressure readings (dbars) were then converted into depth (meters) using the following formula:-

The gravity variation with latitude and pressure is computed as:

$$g \text{ (m/sec}^2\text{)} = 9.780318 * [1.0 + (5.2788 \times 10^{-3} + 2.36 \times 10^{-5} * x) * x] + 1.092 \times 10^{-6} * p$$

where

$$x = [\sin (\text{latitude} / 57.29578)]^2$$

p = pressure (decibars)

Then, depth is calculated from pressure:

$$\text{depth (meters)} = [(((-1.82 \times 10^{-15} * p + 2.279 \times 10^{-10}) * p - 2.2512 \times 10^{-5}) * p + 9.72659) * p] / g$$

Fingal County Council

where

p = pressure (decibars)

g = gravity (m/sec²).

The SBE 39 sensors were sampling every 15 seconds. The results were then averaged over a 10minute period to smooth out fluctuations in pressure caused by surface waves.

The depth recordings from the tide gauges were then adjusted to the vertical offset ordnance survey datum at Malin Head (RTK survey). See section 6

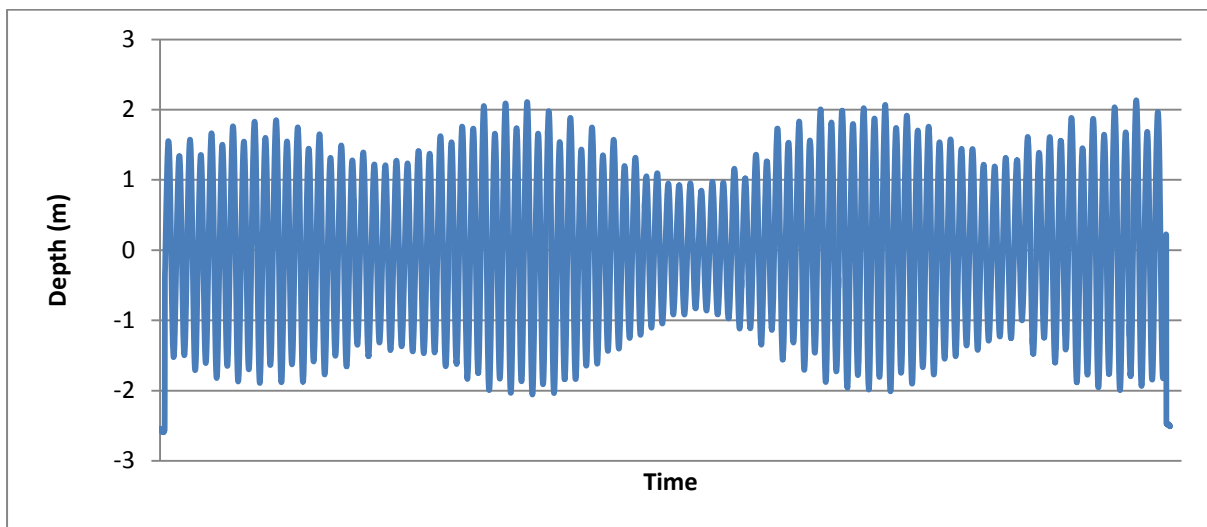

Figure 31. Tidal range data from the SBE 39 tide gauge deployed in **Howth** Harbour.

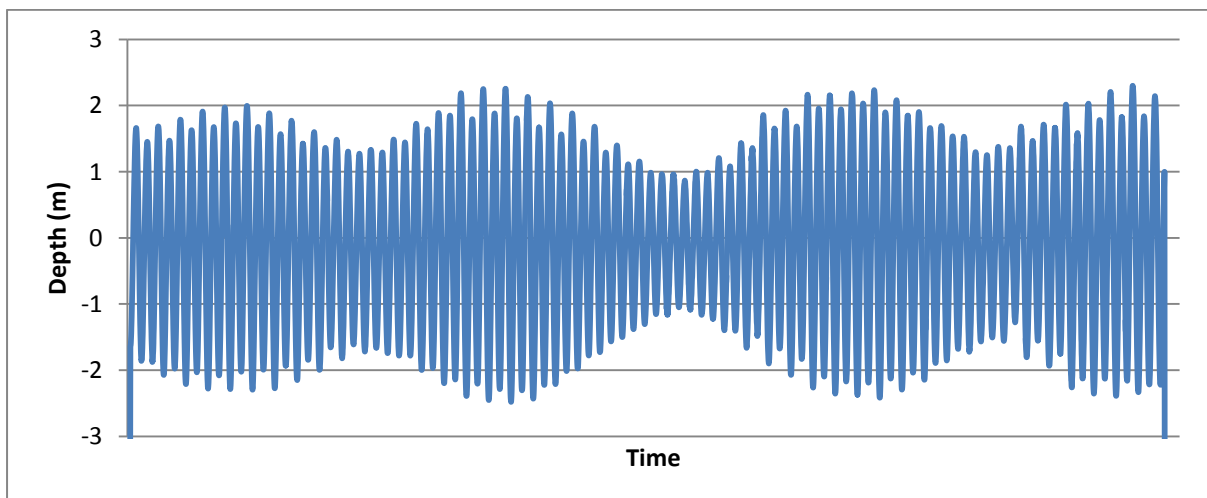

Figure 32. Tidal range data from the SBE 39 tide gauge deployed in **Skerries** Harbour